

Einbautopf

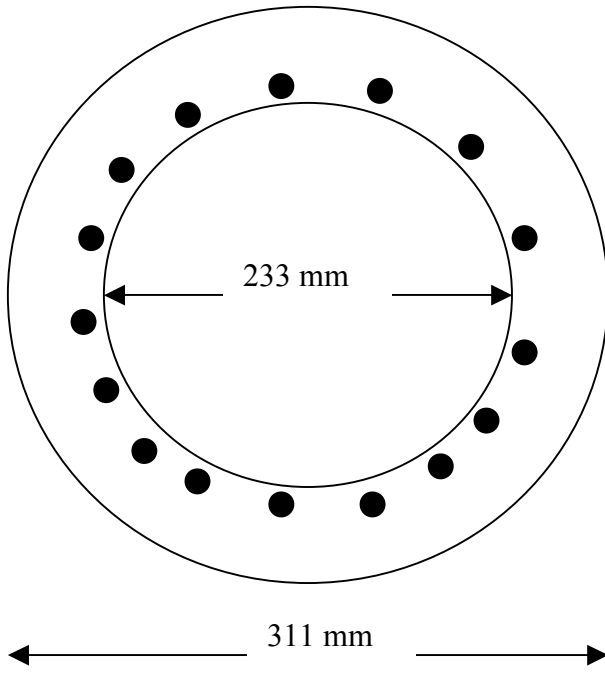

130 mm

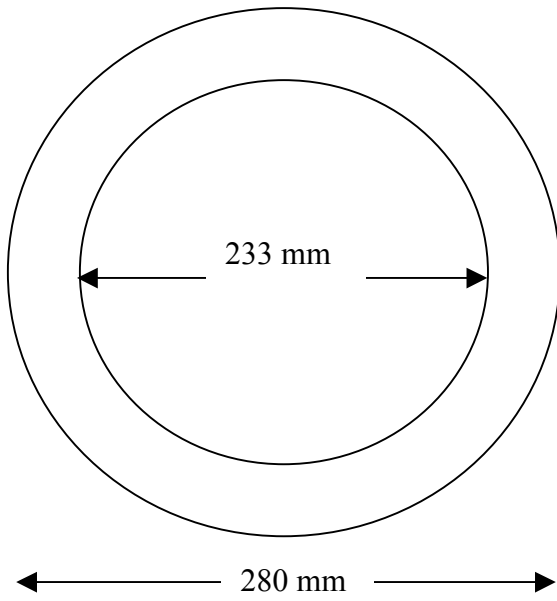
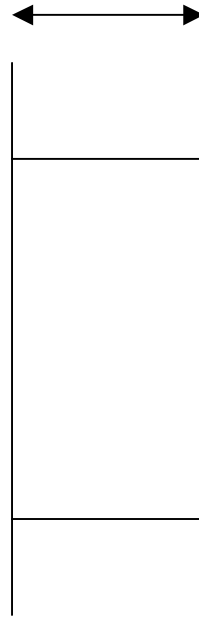

Flansch

# UNDERWATER LIGHT



**► IMPORTANT:** The instruction manual you are holding includes essential information on the safety measures to be implemented for installation and start-up. Therefore, the installer as well as the user must read the instructions before beginning installation and start-up.  
Keep this manual for future reference.

*To achieve optimum performance of the  
underwater light follow the instructions  
provided below:*

## 1. VERIFY THE CONTENTS OF THE PACKING:

The following accessories are included inside the box:

Concrete pool floodlamp

Housing body

Floodlamp unit

Prefabricated pool floodlamp

Housing body

2 watertight joints

Clamp

Floodlamp unit

Bag of screws

16 5,5x25 screws

## 2. GENERAL CHARACTERISTICS:

This floodlamp has been designed to be used fully submerged underwater in fresh water swimming pools. It is a Class III electric apparatus with very low voltage for safety (12V with alternating current).

The floodlamp complies with IPX8 degree of protection (resistance to penetration of dust, solid bodies and humidity) at a nominal immersion depth of 2 m.

This floodlamp complies with international safety standards for lights, especially the EN 60598-2-18 standard. LIGHTS PART 2: SPECIFIC REQUIREMENTS SECTION 18 LIGHTS FOR SWIMMING POOLS AND SIMILAR APPLICATIONS.

The manufacturer is not responsible in any circumstances for assembly, installation or start-up of any electric components which have been inserted or handled at locations other than its own premises.

## 3. INSTALLATION:

- Never install in vertical position with the lamp facing downwards.
- In order to clearly light a pool it is recommended to install a 300W floodlamp every 25 or 35 m<sup>2</sup> of water surface. In swimming pools which are especially deep, a 300W floodlamp is required for every 30 or 40 m<sup>3</sup> of water volume.
- In order to prevent glare, the floodlamps should be installed so that they face away from the residence or usual view of the swimming pool.
- In the event that lighting is used in training or competition pools, the floodlamps should be installed on the sides to prevent glare on the swimmers.
- To avoid the need to empty the pool to change the lamp, we recommend that the floodlamp be installed in areas which are accessible from the upper edge of the pool.

Prior to installation verify that the gland seal (n°8) has been fully tightened.

The floodlamp should be placed on the wall of the pool at approximately 400–700 mm from the water surface (Fig. 1).

The method of fastening the housing to the pool wall varies depending on whether it is a floodlamp for concrete pools or prefabricated pools.

### Concrete swimming pool

To install a floodlamp in a concrete swimming pool the housing (n°9) should be fixed in the wall of the swimming pool (Fig. 2). Make sure that the cable outlet of the housing remains on the upper part.

## Prefabricated swimming pool

To install a floodlamp in a prefabricated swimming pool make a circular hole with a diameter of 270mm (Fig. 2).

From the inner side, introduce the housing (n°12) with one of the gasket (n°11) glued on top of it. Fix the housing on the swimming pool panel using 8 screws or bolts (not included). Once the liner is in position, secure the clamp (n°10) with the other gasket (n°11) using the 16 supplied screws (n°9) (Fig.3).

Make sure that the cable outlet of the housing remains on the upper part.

## 4. ASSEMBLY:

After installation of the housing and the clamp, if it is a prefabricated swimming pool, assemble the floodlamp.

To connect the floodlamp to the electric power supply insert the cable through the gland seal nut (16). Tighten the gland seal nut until you can verify that the cable will not yield when you pull on it with your hand.

Take the precaution of leaving 1.5 m of cable wound on the base of the floodlamp (n°7) in order to be able to remove the floodlamp to the edge of the pool in the event that lamp replacement or handling is required. (Fig. 4).

Insert the entire floodlamp assembly in the housing (Fig 5).

Screw in the two M-6 x 70 screws (n°2) until the fastening dog is secured in the inner walls of the housing (Fig. 7)

## 5. MAINTENANCE:

To remove the floodlamp to the edge of the swimming pool (Fig. 4) loosen the two M-6 x 70 screws (n°2)

To remove the lamp, unscrew the 6 nuts (n°9) which secure the decorative ring (n°1) to the base of the floodlamp (n°5) (Fig. 8).

Remove the lamp (n°3) from the inside of the base of the floodlamp and disconnect the two terminals, loosening the two screws which secure them to the lamp. (Fig. 9).

Change the lamp and assemble the floodlamp, in the opposite order described in point 4 of assembly, taking special care to:

- Connect the cable terminals to the lamp, using the 2 screws supplied with the lamp (Fig. 10).
- Fully centre the 95x7 O-ring (n°4) in its seat.
- Firmly tighten the nuts.

### Attention:

- Before any handling ensure that there is NO voltage supplied to the floodlamp.
- The new lamp should have the same characteristics as that supplied with the floodlamp, PAR 56 300W 12V.
- In order to ensure full watertightness, clean the seat of the O-ring (n°4) for the lamp or replace the O-ring if you observe any notches or permanent damage.

## 6. START-UP:

Ensure that the voltage the lamp receives is never greater than 12 V. The floodlamp should only operate underwater while secured to the vertical walls of the pool. Never switch on the floodlamp if it is not underwater.

## 7. SAFETY WARNINGS:

- The persons who are in charge of assembly should have the required qualifications for this type of work.
- Avoid making contact with the electric voltage.
- Comply with the current standards regarding accident prevention.
- In this regard, the IEC 364-7-702 standards must be observed. WIRING IN BUILDINGS. SPECIAL WIRING. SWIMMING POOLS.
- Any operation related to the maintenance or replacement of parts should be performed with the floodlamp disconnected from the electric power system.
- Do not handle with wet feet.
- The manufacturer is not responsible in any circumstances for assembly, installation or start-up of any electric components which have been inserted or handled at locations other than its own premises.

## CONCRETE POOL

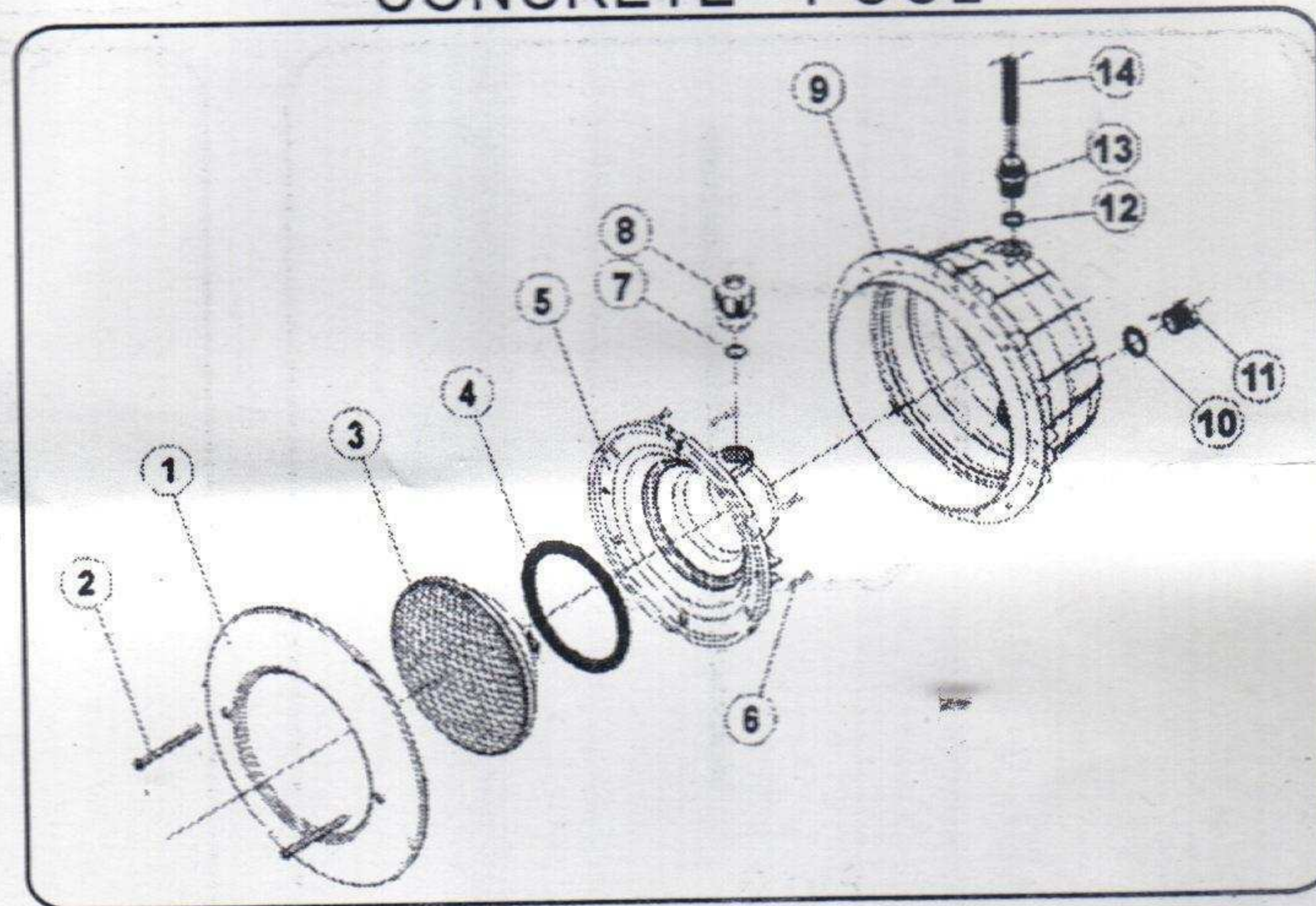

## PREFABRICATED POOL

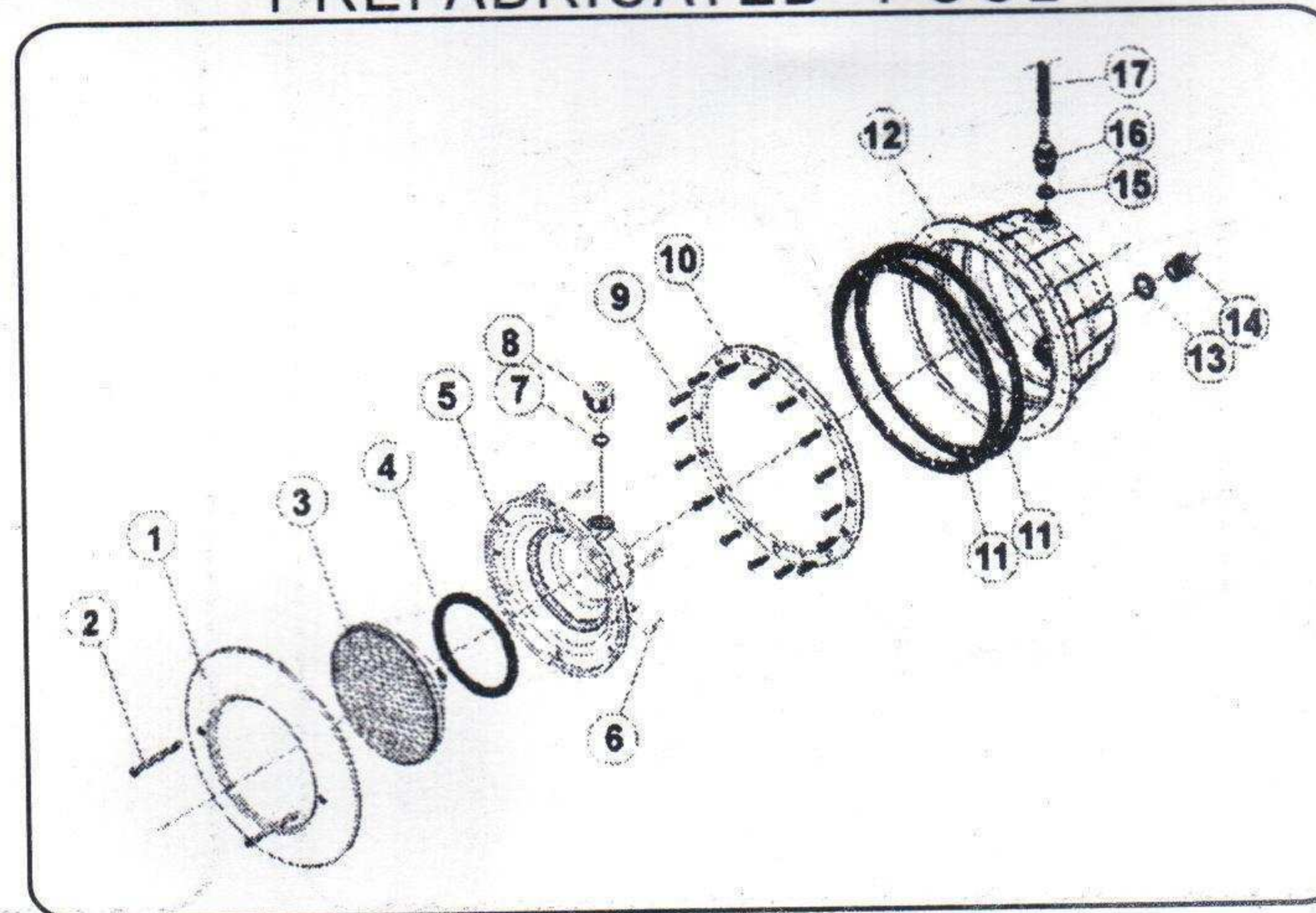

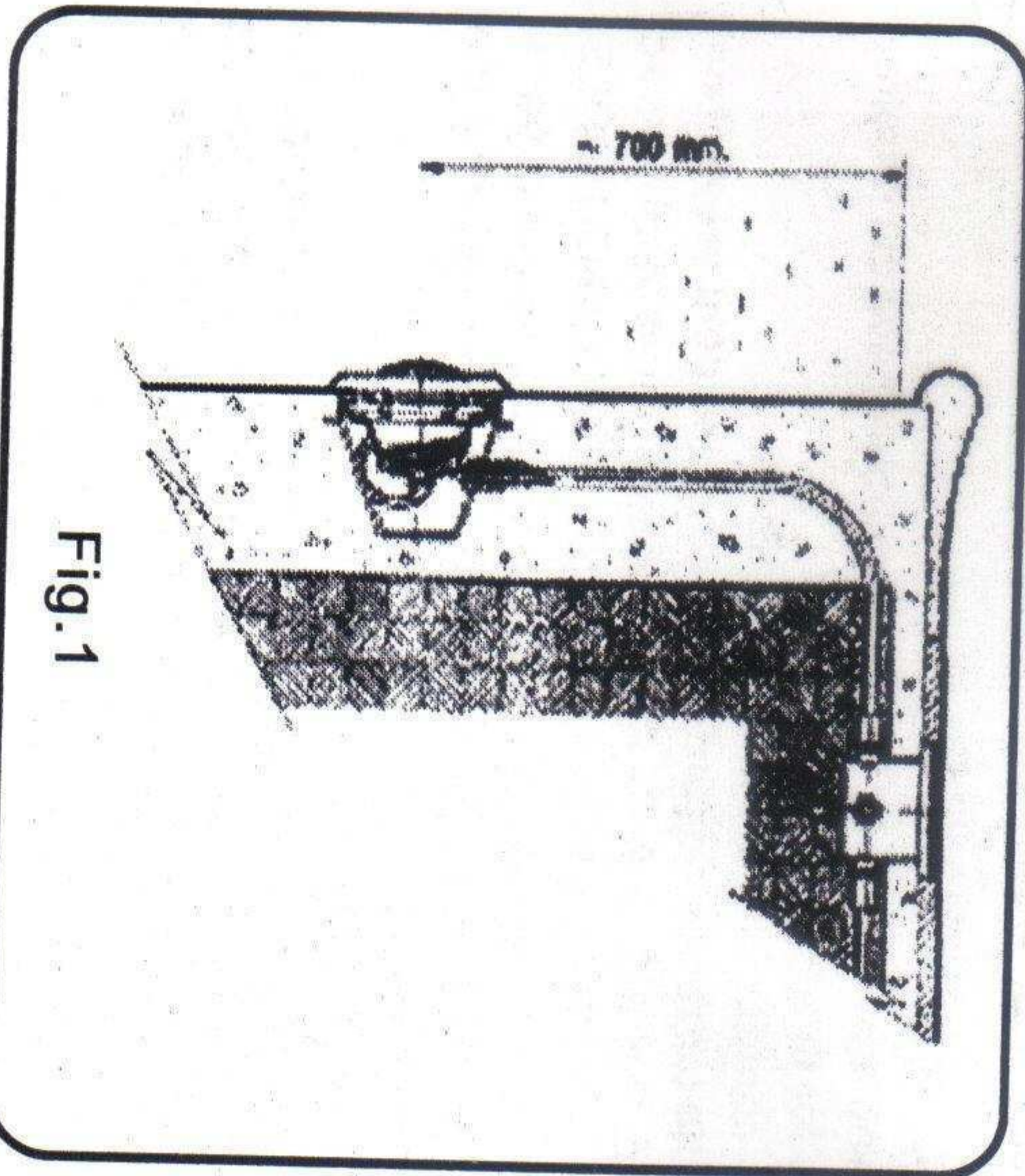
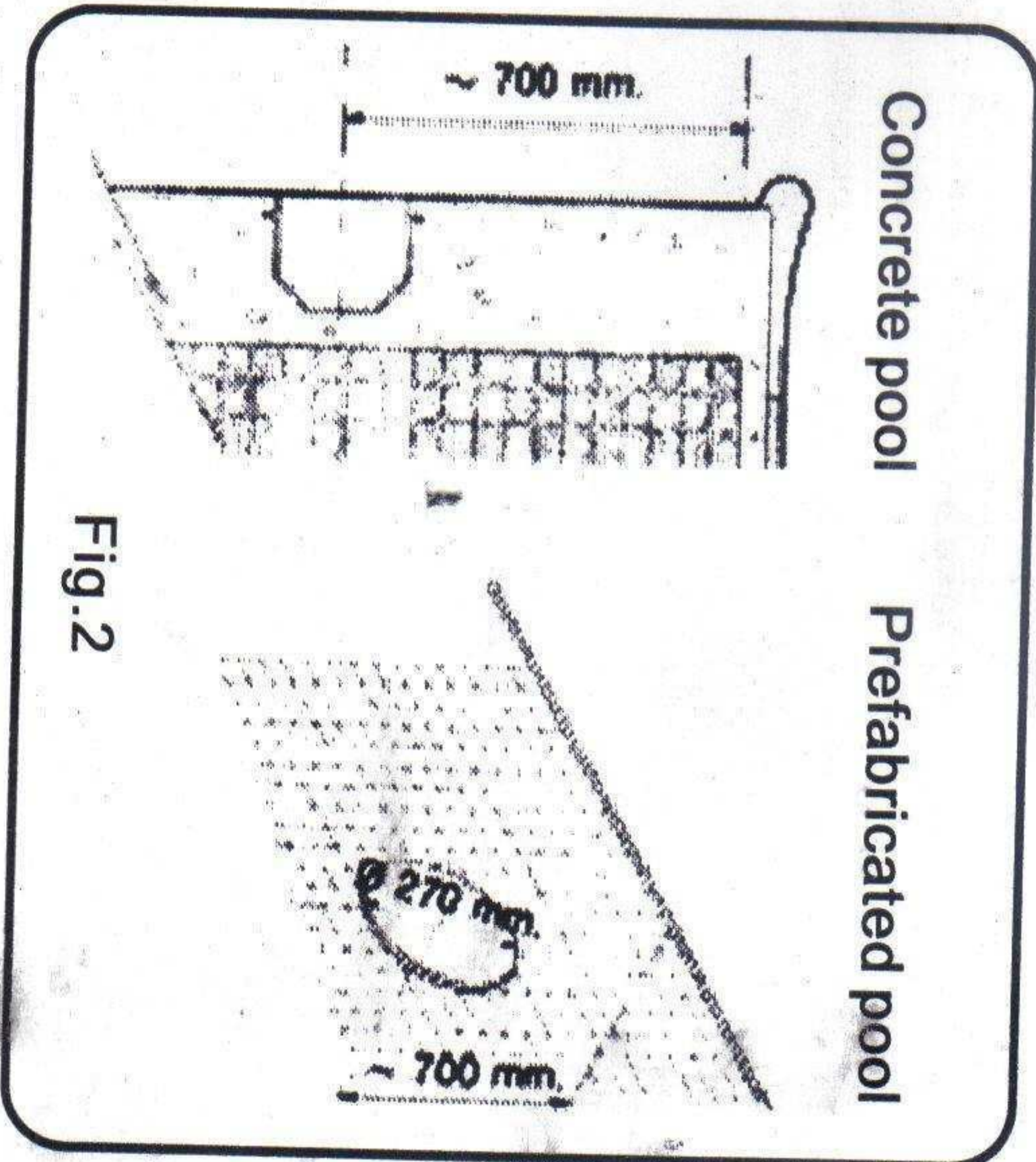

Fig. 1



Concrete pool

Prefabricated pool

Fig. 2

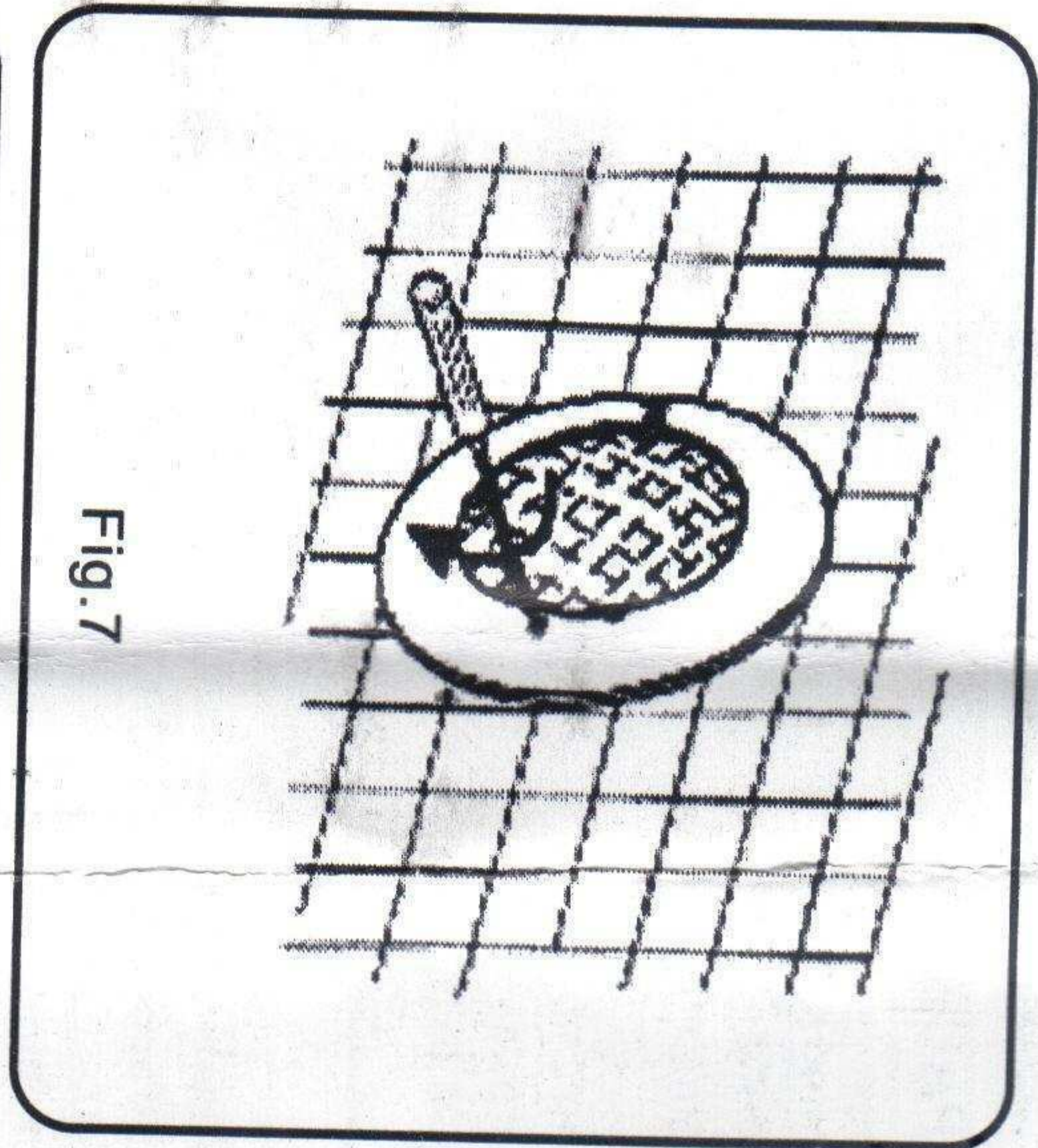

Fig. 7

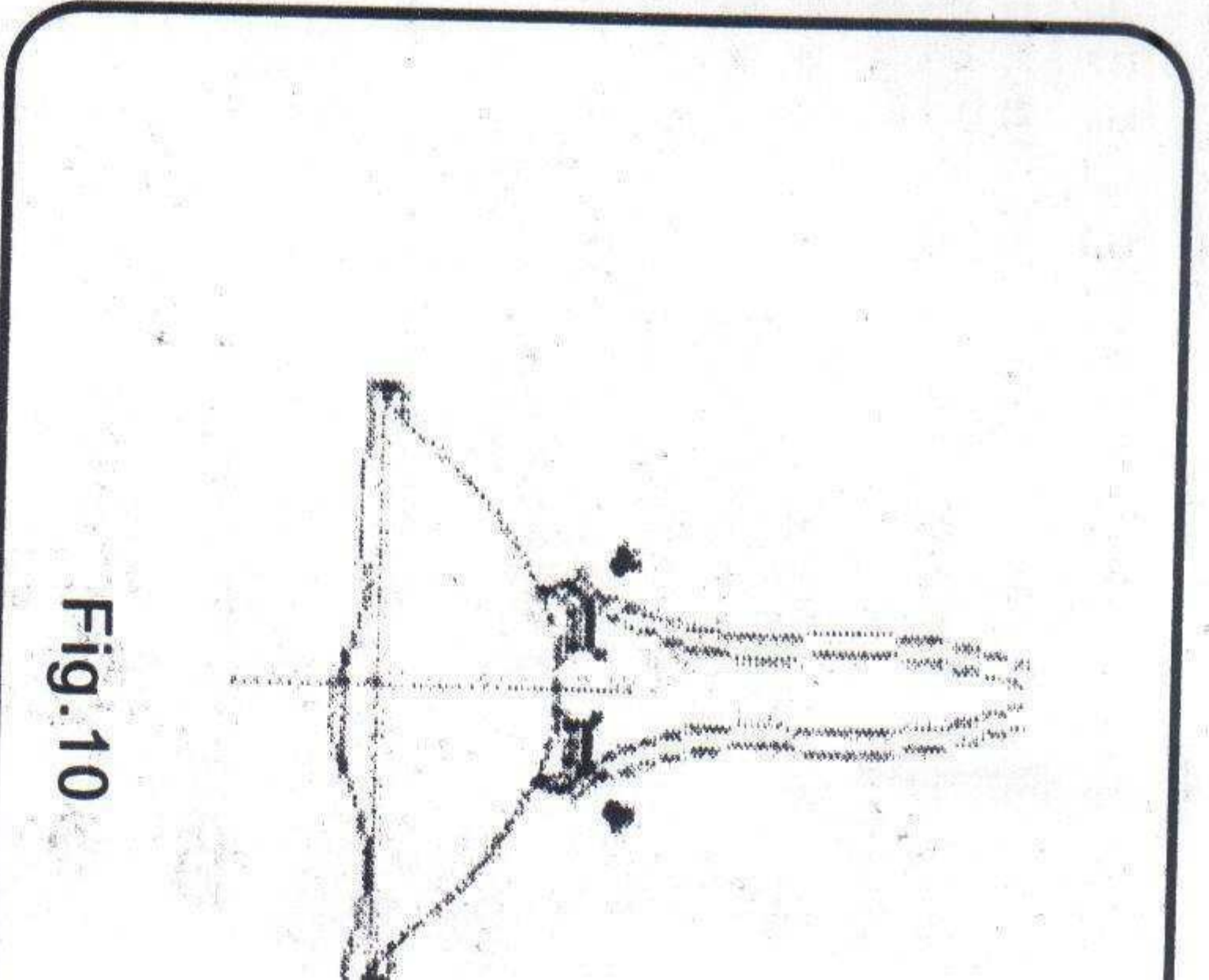

Fig. 10

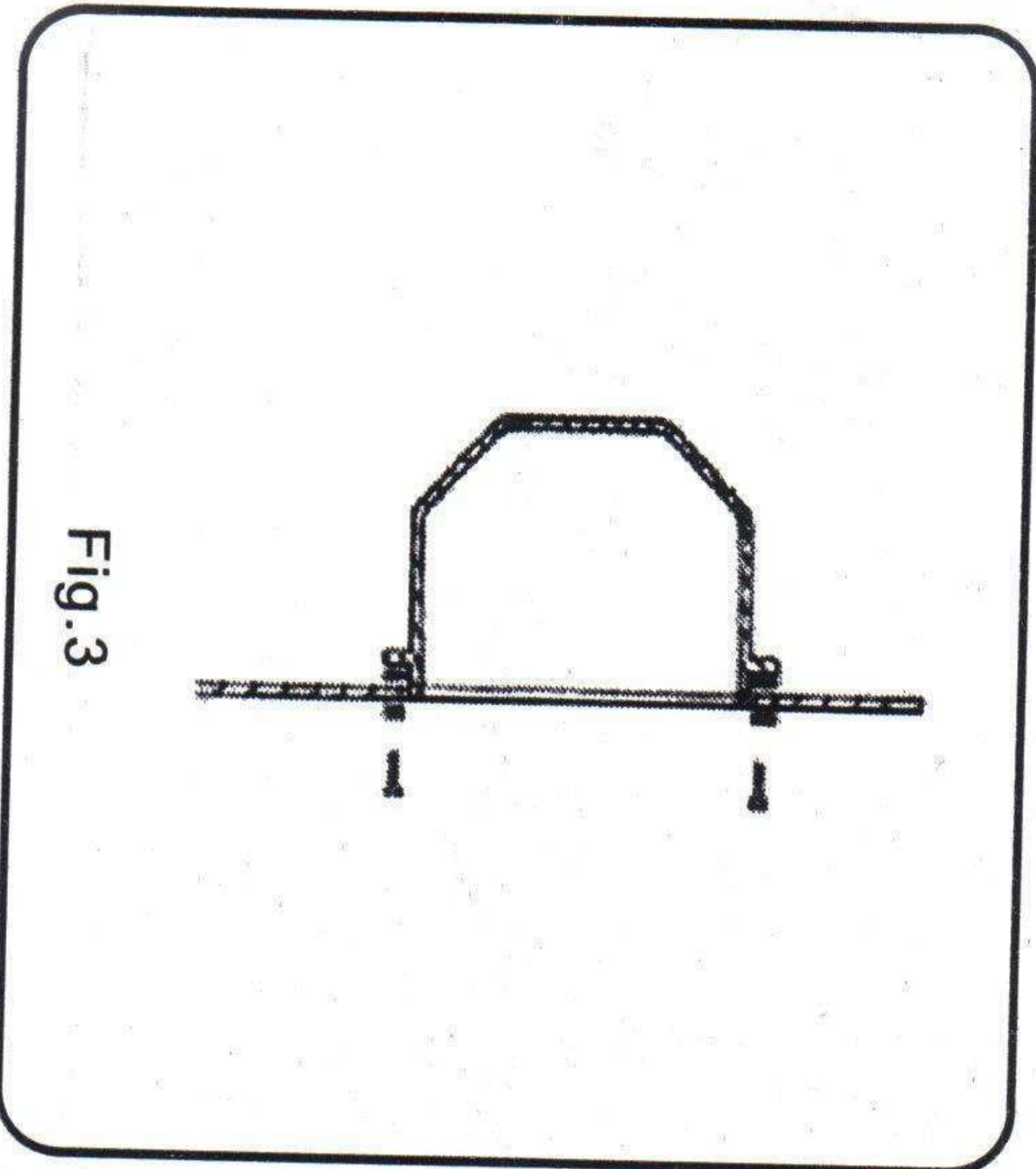

Fig. 3

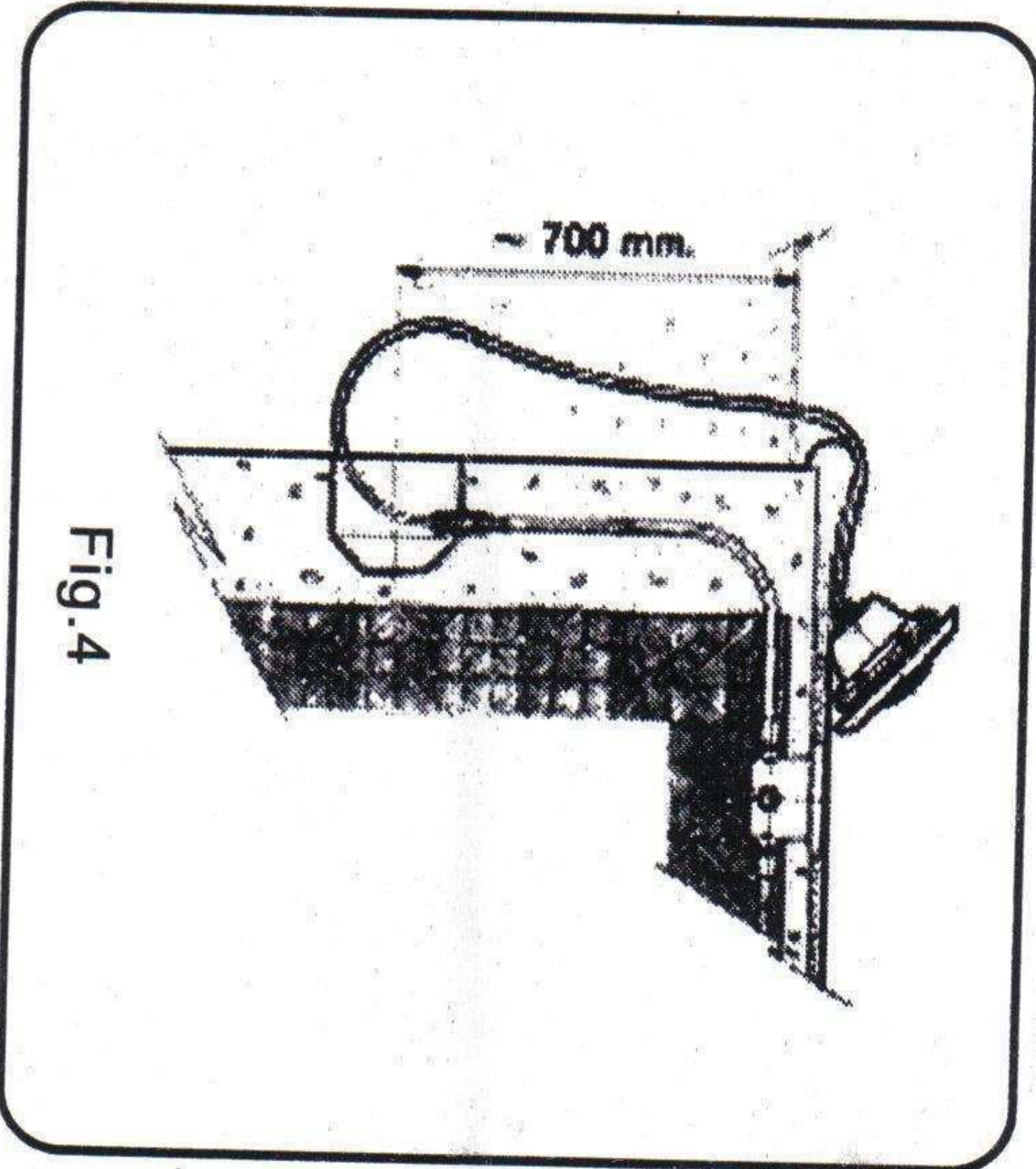

Fig. 4

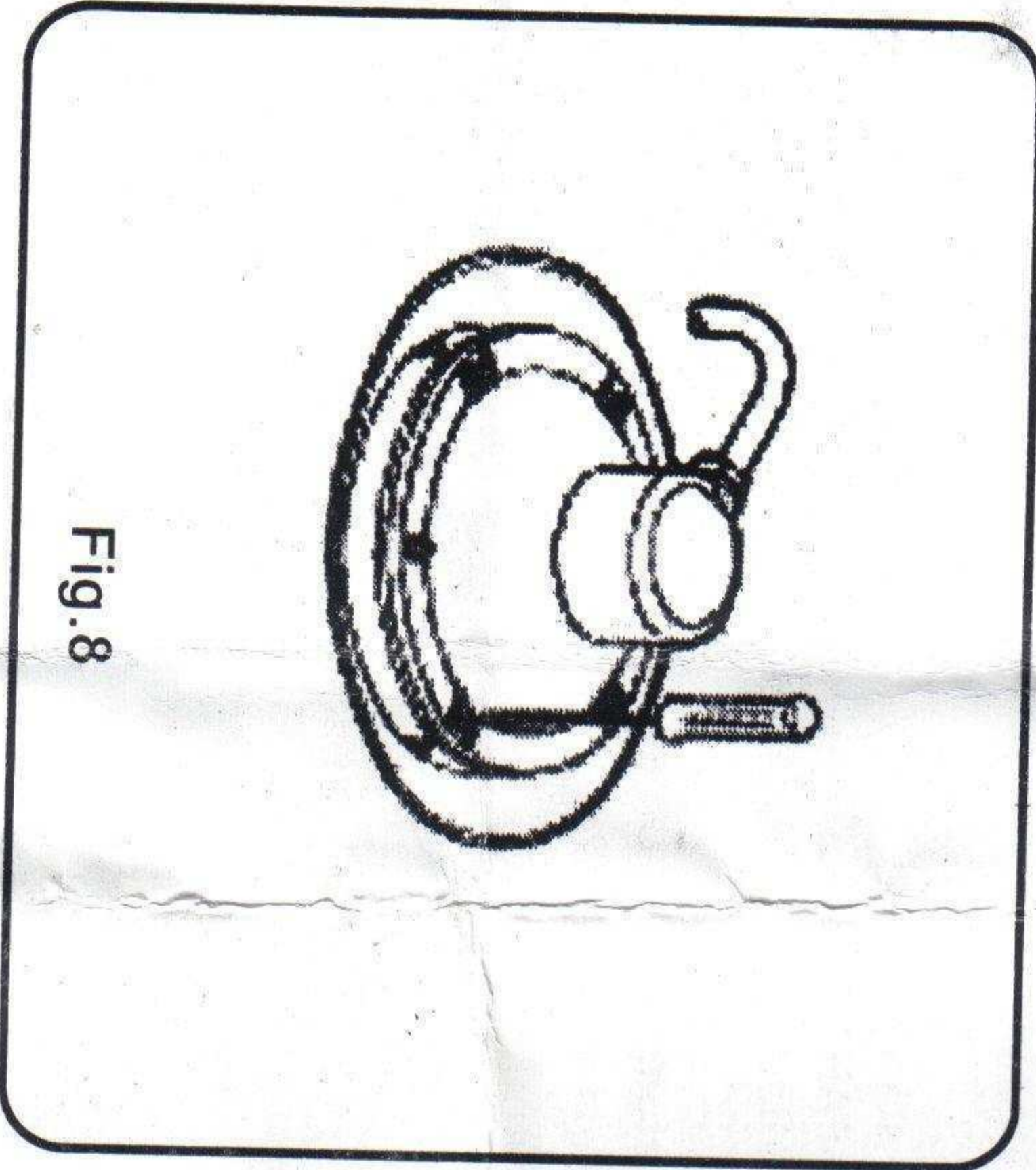

Fig. 8

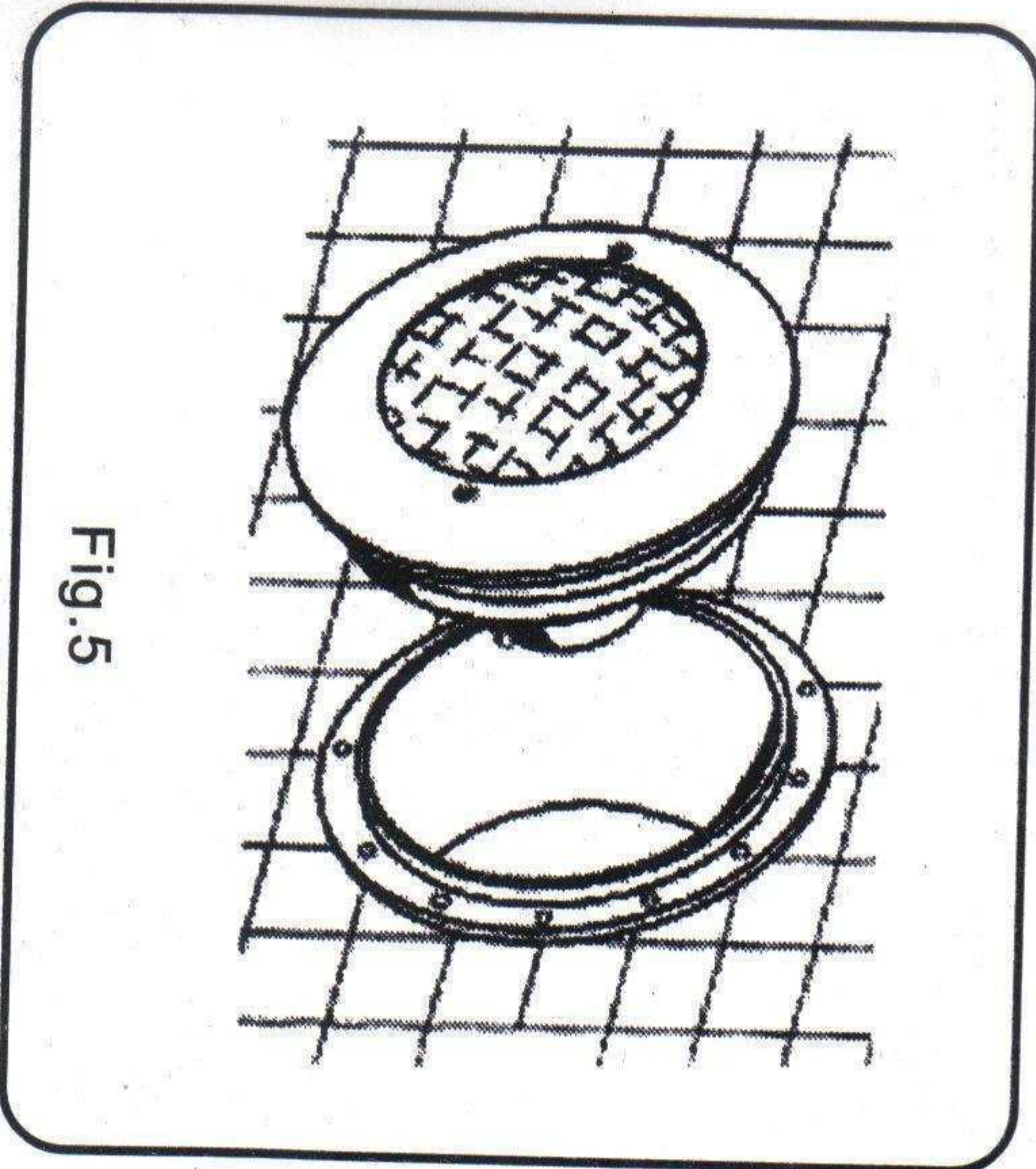

Fig. 5

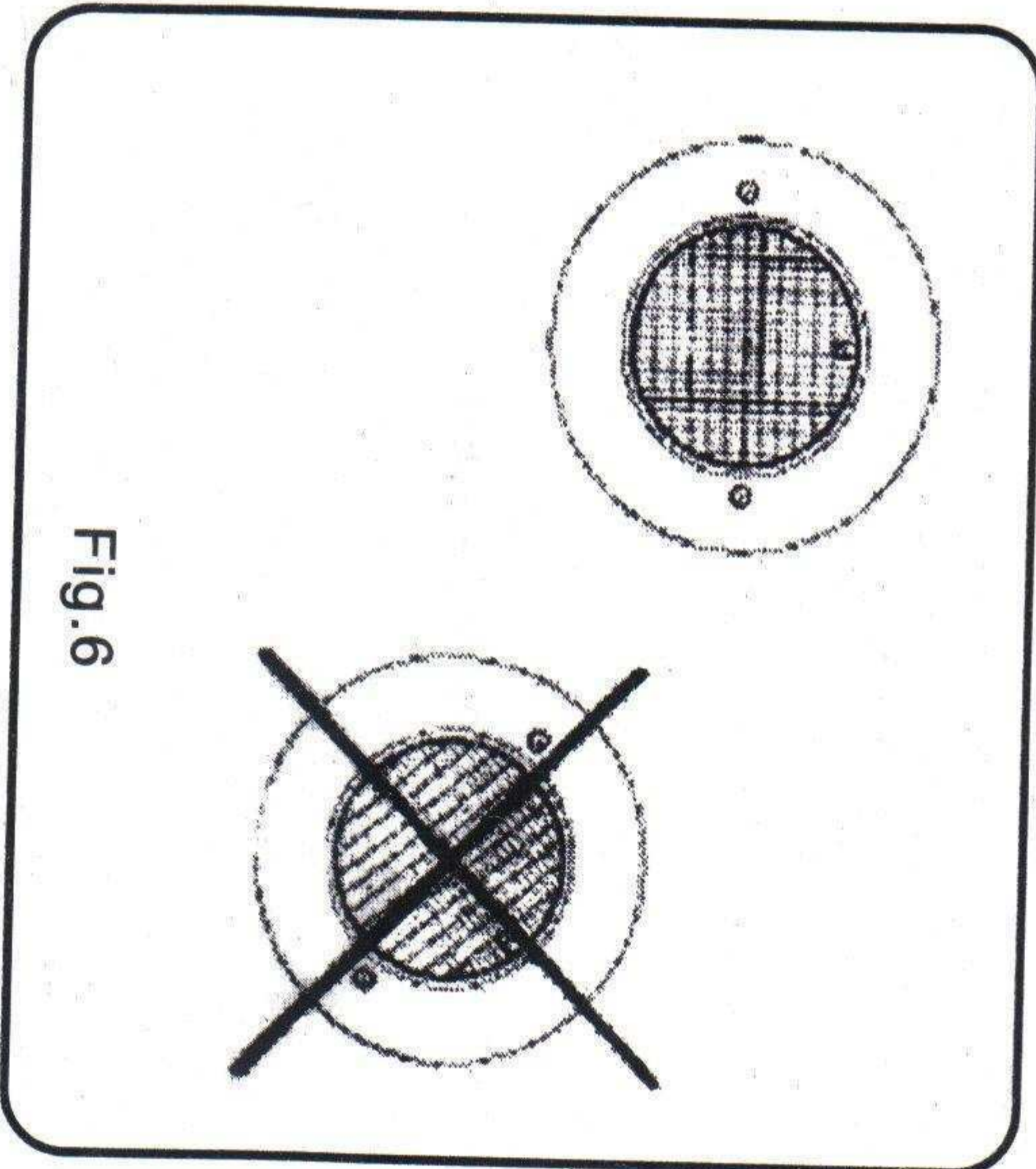

Fig. 6

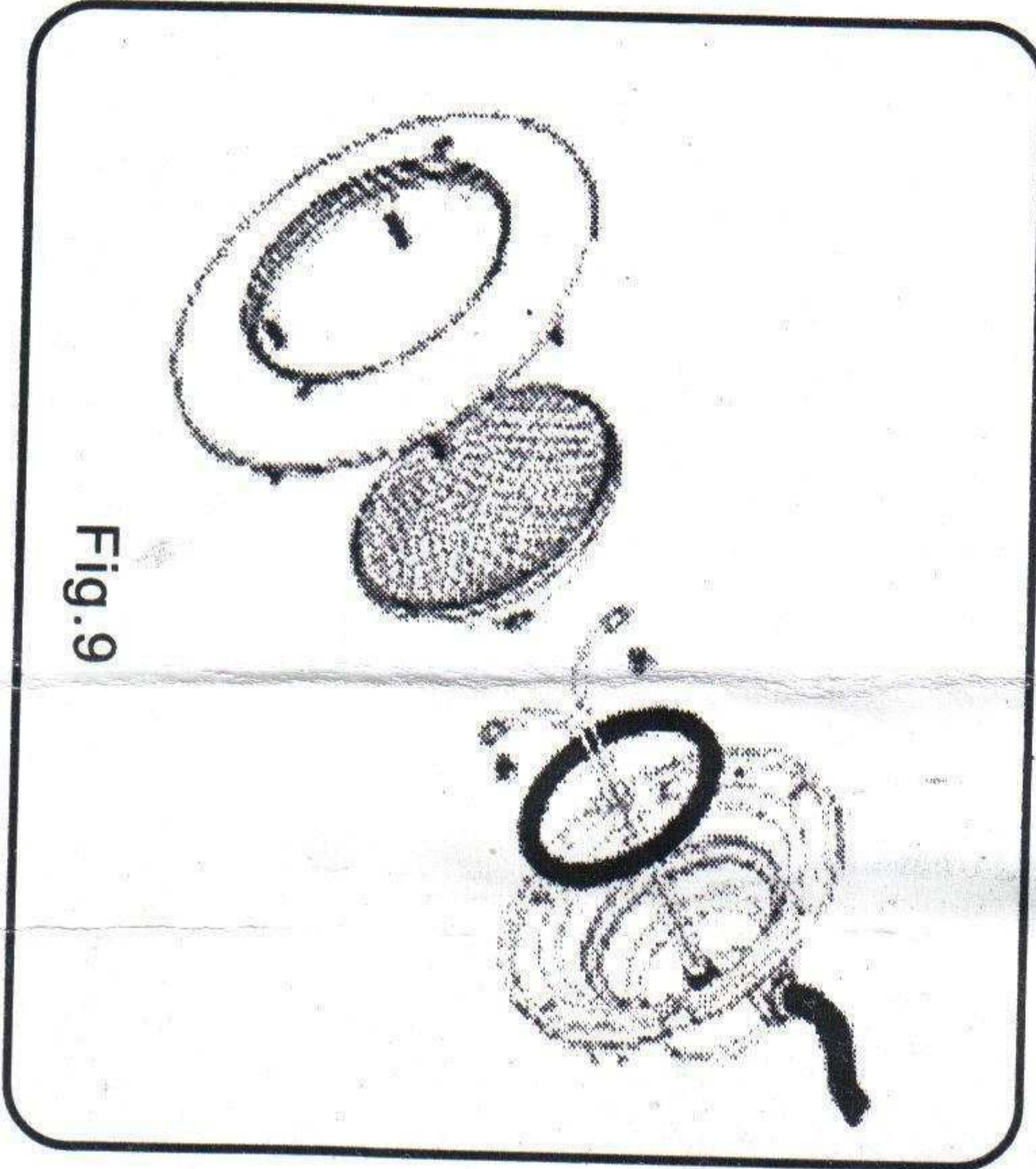

Fig. 9